

DIR21 Digital Infrared Receiver Specifications:

Specifications

Infrared carrier frequency:	30-60kHz
Indoor reception range:	150 feet + (45 meters +)
Outdoor reception range:	35-50 feet (10-15 meters)
Nominal reception angle:	50 degrees off axis
Transmission wire maximum length:	1000' (300m)
Wire requirements:	3 conductor, minimum 24 gauge to 200', 22 gauge up to 500' 20 gauge to 1000'
Power requirements:	Unregulated 12VDC, 40mA
Dimensions:	1-3/4" x 4" x 1" (45mm x 102mm x 26mm)

Requires 12VDC power supply, emitter(s) and DIR54, DIR55 or DIR58 connection block.

Warranty

Knoll Systems warrants its products sold in the USA and Canada by authorized Knoll dealers to be free of defects in materials and workmanship. This warranty extends for three full years from the date of purchase by the original consumer. Any products returned to Knoll Systems and found to be defective by Knoll Systems within the warranty period will be repaired or replaced at Knoll Systems option, at no charge. Knoll Systems will not be responsible for the actual cost of installation or removal of the product, nor for any incidental or consequential damages. Some states do not allow the exclusion or limitation of incidental or consequential damages, so the above limitation may not apply to you. This warranty gives you specific legal rights. You may have additional legal rights that vary from state to state.

Knoll Systems www.knollsystems.com

145 Tye Drive Point Roberts, WA 98281
12140 Horseshoe Way Richmond BC V7A 4V4
tel (604) 272 4555, fax (604) 272 5595
Made in Canada Knoll Systems All Rights Reserved



DIR21

Digital Infrared Receiver Installation Instructions v1.1



Warning: To be installed and/or used in accordance with appropriate electrical codes and regulations.

Introduction: Thank you for your purchase of a Knoll DIR21 digital infrared receiver. This receiver features a long indoor usable range and it can be used in direct sunlight and near plasma and other TV's. It is designed to act as a remote receiver of remote control signals that when passed through a connection module and emitters, relays remote infrared commands to equipment in a distant room.

Features:

- Inwall junction box design, available in white, ivory, almond and black colors.
- Will relay almost all remote control types (except some B&O and Pioneer Elite models).
- Can be connected with almost any 3-conductor wire including cat 5.
- Connects with a three-wire connector or RJ45 via cat 5 wire.
- Requires DIR54, DIR55 or DIR58 connection module, power supply and emitters to work.
- Up to 10 or more DIR21's and other compatible models can be connected in a single system.
- Connects with a three wire connector or RJ45.

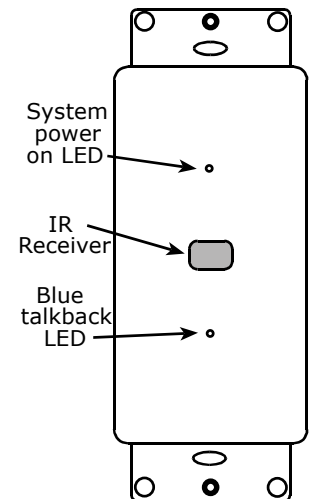

Installation Tips

1. Follow all local electrical & building code requirements.
2. The DIR21 is usually wall mounted at light switch height. It does not normally require a junction box. In order to work it requires a PS1202 (200 mA) or PS1205 (500 mA) 12 VDC unregulated power supply, IR31 (single) or IR34 (dual) emitters and one of the following: DIR54 (decora inwall style, 4 output), DIR55 (tabletop style, 4 output) or DIR58 (wall mount or SMC style, 8 output) connection block.
3. Wires can be solid or stranded, shielded or unshielded with a minimum of 28 gauge for runs under 200', 22 gauge for runs under 500' and 20 gauge for runs up to 1000'. Wires can be looped from DIR21 to DIR21 or home run. Home runs generally offer more reliability and future flexibility.
4. DIR21's can be mixed and matched in larger systems with up to 10 DIR infrared receivers, such as the Knoll DIR10 or DIR25.
5. When using a DIR connection block, connect the DIR21 +12vdc, GND and SIG terminals to the corresponding DIR55 terminal. Prepare the wire leads to and from the DIR receiver by

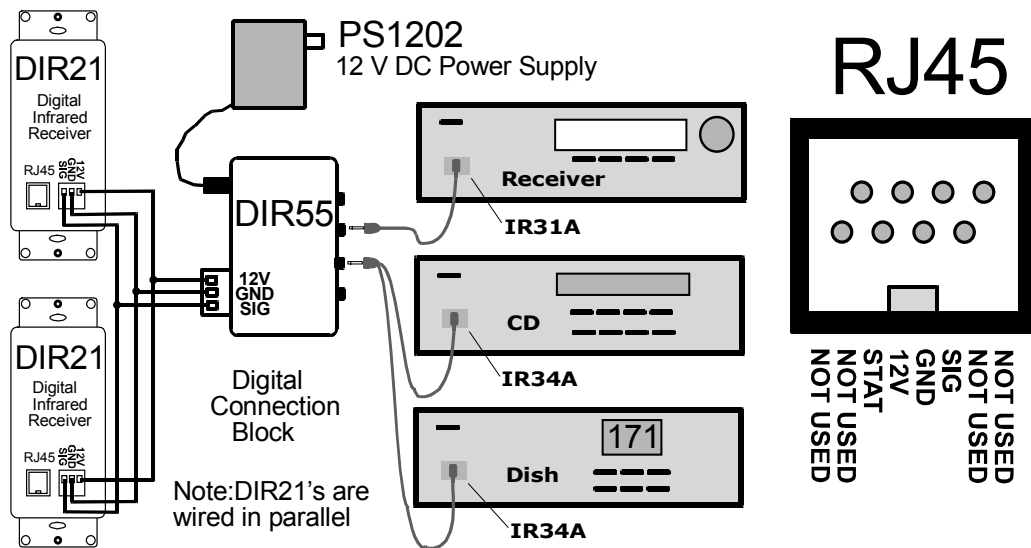

stripping about 1/4" of the insulation from each of the 3 leads. Twist the strands tightly together so that they do not stick out of the connector and cause a short circuit. Be sure to observe polarity. If you are connecting with the RJ45 connector you may need a RJ45 paralleling strip to parallel connect the wires from multiple DIR receivers.

6. Next plug in the single or dual emitters into the DIR connection block.
7. Then plug in the PS1202 (for up to five receivers) or PS1205 for five to eleven receivers.
8. The infrared system is usually left plugged in all the time (to an unswitched outlet) as it uses very little power.
9. Test the digital infrared system to see if it is working properly. If it works only from a very close range or it does not work at all, first mark where the pot adjustment is on the DIR connection block blue color pot. This is so you can reset it to that starting point again. Try adjusting the pot on the connection block very slightly left and right as you are testing the receiver with the remote control. This may require two people. This should correct for the problem. If it still does not work properly, please call Knoll Systems and ask for infrared

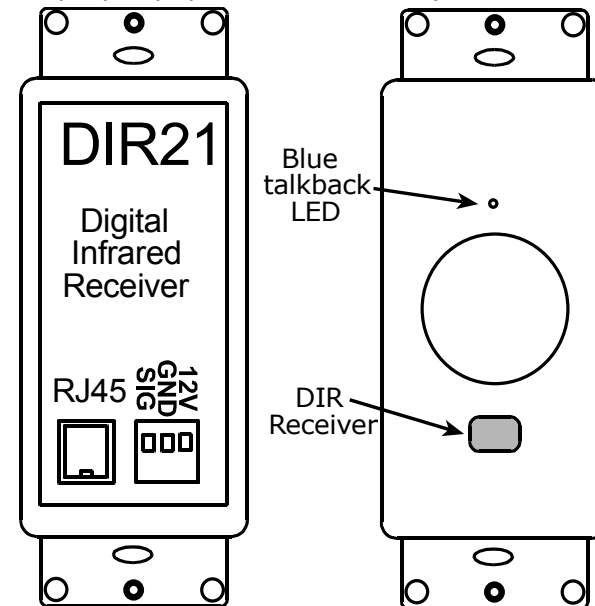

technical support at 1 800 566 5579. The help line is normally open from 7:30 AM to 5:00 PM Monday to Friday Pacific time.