

## IR250 Infrared Receiver Specifications:

### Specifications

Infrared carrier frequency:	30-60kHz
Indoor reception range:	20-25 feet (6-8 meters)
Nominal reception angle:	50 degrees off axis
Maximum wire length:	1000' (300m) or even more with larger gauge wire
Wire requirements:	3 conductors, minimum 24-gauge to 200'; 22-gauge up to 500'; 20-gauge to 1000'
Power requirements:	Unregulated 12VDC, 40mA
Dimensions:	1.38" x 1.38" x 0.59" (35mm x 35mm x 15mm)

**Requires 12VDC power supply, emitter(s) and IR54, or IR55 connection block.**

### Warranty

Knoll Systems warrants its products sold in the USA and Canada by authorized Knoll dealers to be free of defects in materials and workmanship. This warranty extends for three full years from the date of purchase by the original consumer. Any products returned to Knoll Systems and found to be defective by Knoll Systems within the warranty period will be repaired or replaced at Knoll Systems option, at no charge. Knoll Systems will not be responsible for the actual cost of installation or removal of the product, nor for any incidental or consequential damages. Some states do not allow the exclusion or limitation of incidental or consequential damages, so the above limitation may not apply to you. This warranty gives you specific legal rights. You may have additional legal rights that vary from state-to-state.

**Knoll Systems [www.knollsystems.com](http://www.knollsystems.com)**

145 Tyee Drive Point Roberts, WA 98281  
12140 Horseshoe Way, Richmond, BC V7A 4V4  
Telephone: (604) 272-4555, Fax (604) 272-5595  
Made in Canada Knoll Systems All Rights Reserved



## IR250

### Postage Stamp Infrared Receiver Installation Instructions v1.1



**Warning:** To be installed and/or used in accordance with appropriate electrical codes and regulations.

**Introduction:** Thank you for your purchase of a Knoll IR250 infrared receiver. This receiver features the ability to pick up a remote control infrared signal and relay it on wires to another location up to 1000' (or more).

### Features:

- Very small design available in black and light grey colors.
- Will relay almost all remote control types (except some B & O models).
- Requires very little power. Suggest using PS1202 12 VDC 200 mA for up to 5 IR250's.
- Up to 10 or IR10, IR21, IR22, IR230 and or IR250 can be connected in a single system.
- Connects with a three wire connector or RJ45 via cat 5 wire

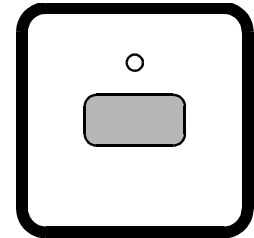

### Installation Tips

1. Follow all local electrical & building code requirements.
2. The IR250 is usually mounted to the wall using double sided tape. For easy installation and to ensure reliability, it is suggested that a PS1202 (200 mA) or PS1205 (500 mA) 12 VDC unregulated power supply, IR31 (single) or IR34 (dual) emitters and one of the following: IR54 (decora inwall style, 4 output) or IR55 (tabletop style, 4 output) connection block, are used.
3. Wires can be solid or stranded, shielded or unshielded with a minimum of 28-gauge for runs under 200', 22-gauge for runs under 500' and 20-gauge for runs up to 1000'. Wires can be

looped from IR250 to IR250 or home run. Home runs normally offer more reliability and future flexibility.

4. IR250s can be mixed and matched in larger systems with up to 10 infrared receivers, such as the Knoll IR21, IR22 or IR10.

5. To wire the system together, connect the IR250 **12V**, **GND** and **SIG** terminals to the corresponding IR54 or IR55 terminal. Prepare the wire leads to and from the IR250 by stripping about ¼" of the insulation from each of the three leads. Twist the strands tightly together so that they do not stick out of the connector and cause a short circuit. Strictly observe polarity. If you are connecting with the RJ45 connector you may need a RJ45 paralleling strip to parallel connect the wires from multiple IR receivers.

6. Next, plug the single or dual emitters into the IR54 or IR55 connection block.

7. Now plug in the PS1202 (for up to five receivers) or PS1205 for five to ten receivers.

8. The infrared system is usually left plugged in all the time (to an unswitched outlet) as it uses very little power.

9. Test the infrared system to see if it is working properly. Bright sunlight and passive infrared security systems can lower the distance that remote controls can work with an IR250 receiver. If you have any questions or concerns, please call and ask for infrared technical support at 1 800 566 5579. The help line is open from 7:30 a.m. to 5:00 p.m., Monday to Friday, Pacific time.

## IR250 system typical layout

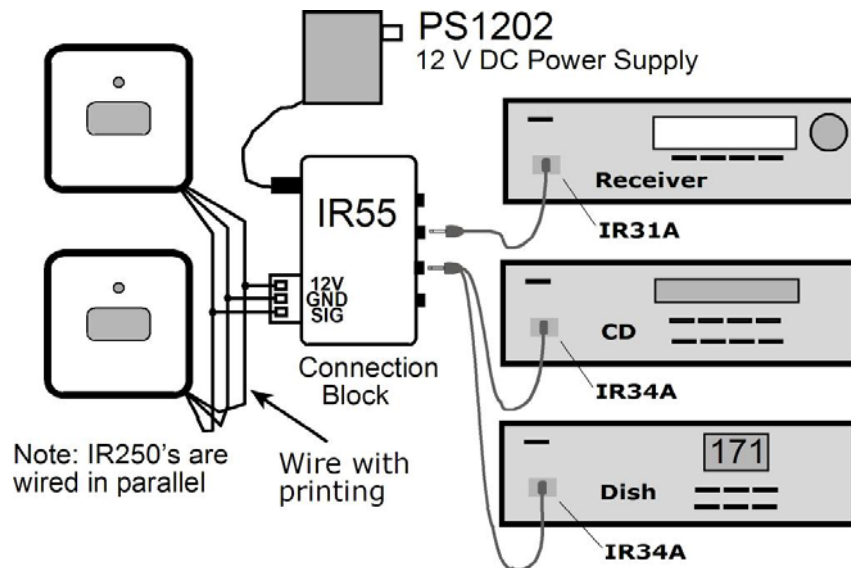

## IR250 front and wiring identification

