

IR54

Infrared Connection Module

Information and Installation Guide

v 1.2

Typical IR Repeater System

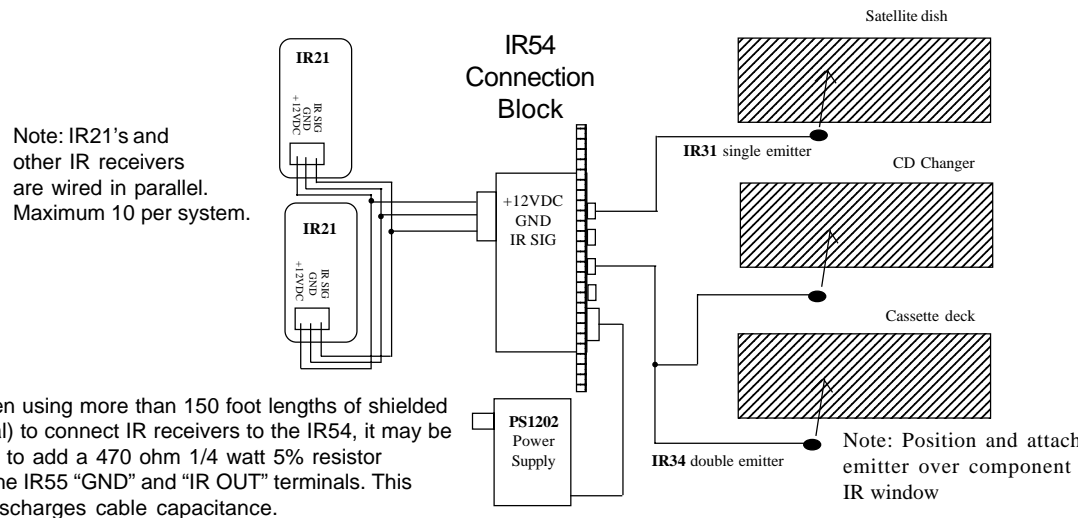

IR54 Features

- * Easy to install, easy to use!
- * No maintenance or adjustments
- * Connect up to 10 infrared receivers
- * Connect up to 8 emitters (four IR34 double emitters)
- * Connect a PS1202 or PS1205 power supply

Specifications

Infrared carrier frequency: 30-60kHz
 Power requirements: PS1202 200mA or PS1205 500mA unregulated 12VDC power supply
 Dimensions: 4.1" h x 1.5" w x 1.5" deep (104 x 38 x 38mm).
 Color: White, almond ivory or black decora style

Installation Tips:

1. Follow all local electrical & building code requirements.
2. The IR54 is usually positioned behind the stereo components it is helping to control.
3. Connect all of the infrared receivers in parallel to the IR54 three terminal connector as shown in the diagram. Wires can be solid or stranded, shielded or unshielded with a minimum of 24 gauge for runs under 200', 22 gauge for runs under 500' and 20 gauge for runs up to 1000'. Wires can be looped from IR receiver to receiver or home run. Home runs generally offer more reliability and future flexibility.
4. Connect the emitters by inserting their plugs into any available IR54 emitter jack. Up to four single emitter or double emitters (maximum eight emitters) can be connected to a single IR54. If more emitter connections are required, call Knoll for amplified connection block information.

5. Lastly plug the PS1202 or PS1205 power supply into the IR54 and test the whole system.

Warranty

Knoll Systems warrants its products sold in the USA by authorized Knoll Systems dealers to be free from defects in materials and workmanship. The warranty extends for two full years from the date of purchase by the original consumer. Any products returned within the warranty period will be repaired or replaced at Knoll Systems option, at no cost. Knoll Systems will not be responsible for the actual cost of removal or reinstallation of the product, nor of any incidental or consequential damages. Some states do not allow the exclusion or limitation of incidental or consequential damages, so the above limitations may not apply to you. This warranty gives you specific legal rights. You may have additional legal rights that vary from state to state.

Knoll Systems
 145 Tyee Drive
 Point Roberts, WA 98281

